



**ALL GLASS
PARTS INC**
HARDWARE - TOOLS - SUPPLIES

ITEM: 19-402AL

18139 - 107 Avenue
Edmonton, Alberta T5S 1K4
Canada
Phone Toll-Free: (800) 661-9951
Fax Toll-Free: (877) 484-1209

19-402AL - Optima 150 - Glass Door Wall Mount Single Sliding System (Aluminum)

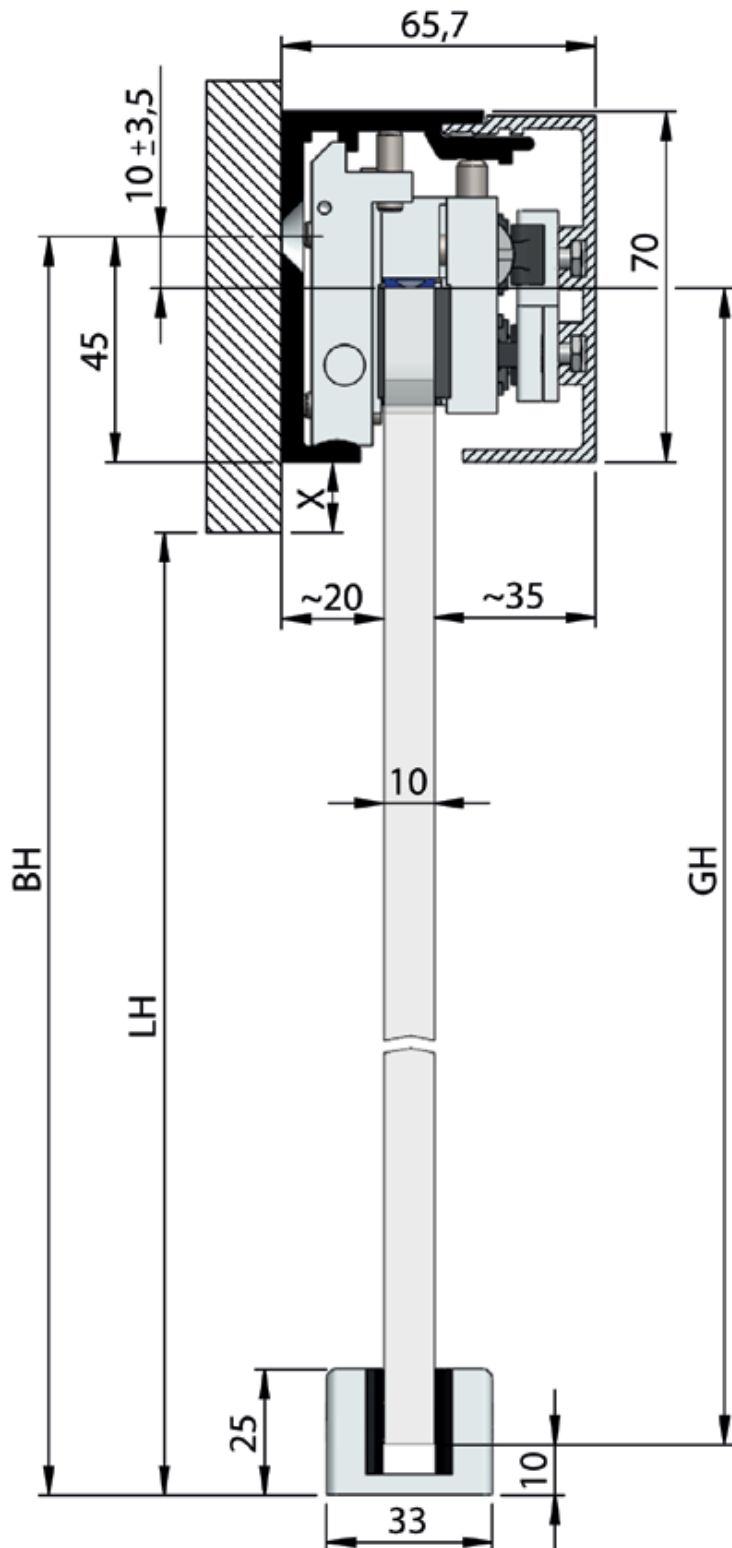

Mounting: Wall mount version single door.

Door weight max. 330 lbs.

Glass thickness laminated safety glass: 5/16 - 1/2" (tempered glass).

Glass thickness: 5/16 - 1/2" (tempered glass).

Material: Aluminum.

Kit includes:

- 2 Roller units incl. clamps
- 2 Stoppers
- 1 Running track, wall mounting incl. cover
- 1 bottom guide

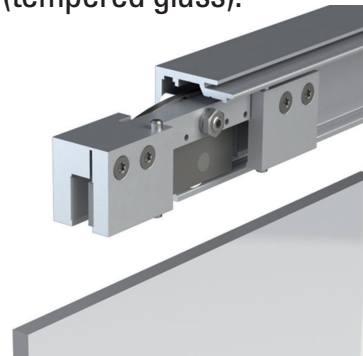

Available Separate

19-402-CAP - Optima 150 - Glass Door Removable Cover Caps



19-402-CLOSE - Optima 150 - Glass Door Smart Stop Damping System

